



深圳市锐硕光电有限公司

SPECIFICATIONS FOR T1S SERIES

WHITE LED

Model: 1616

Part No: T1Sxxx12A-xxx6/9xx

Features:

- * Thermally Enhanced Package Design
- * Mid Power to High Power, up to 0.7W
- * Max. Driving Current 200mA
- * High Color Quality with CRI Min. 80
- * Pb-free Reflow Soldering Application

**Applications**

- * Retrofits (replacement)
- * General lighting
- * Indoor & Outdoor sign board back light
- * Architectural / Decorative lighting

Part Numbering System

T □□ □□ □ □ □ □ - □□ □□

X1 X2 X3 X4 X5 X6 X7 X8

Item Number Code	Description	Content
X1	Type code	1S:1616;34:3020; 3A:K285; 3B:3014; 3C:3030; 5A:5050N; 32: 3528; 19: Ceramic 3535; 15: Ceramic 5050; 12: Ceramic 9292; 20: 2016.
X2	CCT code	2725±145K: 27 3045±175K: 30 3465±245K: 35 3985±275K: 40 5028±283K: 50
X3	Color Rendering	Ra70:7; Ra80:8; Ra90:9.
X4	No. of serial chip	1-Z.
X5	No. of parallel chip	1-Z.
X6	Component code	A-Z.
X7	Color Code	\
X8	Internal code1	\

Electro Optical Characteristics, IF = 150mA, Ta=25°C, RH60%

CCT	Color Rendering	Luminous Flux	
		Ta=25°C	
	Min.	Typ.	Min.
1800K	80	42	36
	90	38	32
2200K	80	51	42
	90	46	38
	95	42	34
2700K	80	58	50
	90	52	42
	95	48	38
3000K	80	60	50
	90	53	42
	95	49	38
3500K	80	62	54
	90	55	46
	95	51	42
4000K	80	65	54
	90	58	46
	95	53	42
5000K	80	65	54
	90	58	46
	95	53	42
5700K	80	65	54
	90	58	46
	95	53	42
6500K	80	65	54
	90	58	46
	95	53	42

- * Tolerance of measurements of the Luminous Flux is $\pm 7\%$.
- * Ra measurement tolerance is ± 2 .
- * Correlated Color Temperature is derived from the CIE 1931 Chromaticity diagram.
- * The lumen table at 85°C is only for reference.
- * Ta = 25°C, RH60%
- * All measurements were made under the standardized white high reflection PCB .

Absolute Maximum Ratings at Ta=25°C

Item	Symbol	Absolute Maximum Rating	Unit
Forward current	IF	200	mA
Pulse Forward current	IFP	300	mA
Power Dissipation	PD	700	mW
Reverse Voltage	VR	5	V
Operating Temperature	Topr	-40~+100	°C
Storage Temperature	Tstg	-40~+100	°C
Junction Temperature	Tj	125	°C
Soldering Temperature	Tsld	230°C or 260°C for 10sec	

* IFP condition with Pulse: Width≤100μs, Duty cycle≤1/10.

* LED's properties might be different from suggested values like above and below tables if operation condition will be exceeded our parameter range. Care is to be taken that power dissipation does not exceed the absolute maximum rating of the product.

* All measurements were made under the standardized environment of Lightning LED.

Electrical/Optical Characteristics at Ta=25°C

Item	Symbol	Min	Typ	Max	Unit	Condition
Forward Voltage	VF	-	3.3	3.5	V	IF=150mA
Reverse Current	IR	-	-	10	μA	VR=5V
View Angle-0.90mm	$2\theta_{1/2}$	-	170	-	°	IF=150mA
View Angle-0.63mm	$2\theta_{1/2}$	-	135	-	°	IF=150mA
Thermal Resistance	(Rth j-sp)	-	22	-	°C/W	IF=150mA
Electrostatic Discharge	ESD	-	1000	-	V	-

*Tolerance : VF :±0.1V

* $2\theta_{1/2}$ is the off-axis where the luminous intensity is 1/2 of the peak intensity.

* Thermal resistance : RthJS (Junction / solder)

* Ta = 25°C, RH60%

Bin Structure

Luminous Flux Ranks, IF = 150mA, Ta =25°C

CCT	Color Rendering		Luminous Flux		
	Min.	Typ.	Code	Min	Max
18MA/MB/MC	80	82	E2	36	38
			E3	38	42
			E4	42	46
			E5	46	50
22M3/MA/MB/MC/MD	80	82	E4	42	46
			E5	46	50
			E6	50	54
			E7	54	58
27M3/MA/MB/MC/MD	80	82	E6	50	54
			E7	54	58
			E8	58	62
			E9	62	66
30M3/MA/MB/MC/MD	80	82	E6	50	54
			E7	54	58
			E8	58	62
			E9	62	66
35M3/MA/MB/MC/MD	80	82	E7	54	58
			E8	58	62
			E9	62	66
			F1	66	70
40M3/MA/MB/MC/MD	80	82	E8	58	62
			E9	62	66
			F1	66	70
			F2	70	74
50M3/MA/MB/MC/MD	80	82	E8	58	62
			E9	62	66
			F1	66	70
			F2	70	74
57M3/MA/MB/MC/MD	80	82	E8	58	62
			E9	62	66
			F1	66	70
			F2	70	74
65M3/MA/MB/MC/MD	80	82	E8	58	62
			E9	62	66
			F1	66	70
			F2	70	74

* Tolerance of measurements of the Luminous Flux is $\pm 7\%$.

* Ra measurement tolerance is ± 2 .

Bin Structure

Luminous Flux Ranks, IF = 150mA, Ta =25°C

CCT	Color Rendering		Luminous Flux		
	Min.	Typ.	Code	Min	Max
18MA/MB/MC	90	92	D9	34	36
			E2	36	38
			E3	38	42
			E4	42	46
22M3/MA/MB/MC/MD	90	92	E3	38	42
			E4	42	46
			E5	46	50
			E6	50	54
27M3/MA/MB/MC/MD	90	92	E4	42	46
			E5	46	50
			E6	50	54
			E7	54	58
30M3/MA/MB/MC/MD	90	92	E5	46	50
			E6	50	54
			E7	54	58
			E8	58	62
35M3/MA/MB/MC/MD	90	92	E5	46	50
			E6	50	54
			E7	54	58
			E8	58	62
42M3/MA/MB/MC/MD	90	92	E6	50	54
			E7	54	58
			E8	58	62
			E9	62	66
50M3/MA/MB/MC/MD	90	92	E6	50	54
			E7	54	58
			E8	58	62
			E9	62	66
57M3/MA/MB/MC/MD	90	92	E6	50	54
			E7	54	58
			E8	58	62
			E9	62	66
65M3/MA/MB/MC/MD	90	92	E6	50	54
			E7	54	58
			E8	58	62
			E9	62	66

* Tolerance of measurements of the Luminous Flux is ±7%.

* Ra measurement tolerance is ±2.

Forward Voltage Ranks, IF = 150mA, Ta =25°C

Code	Min	Max	Unit
E	2.8	2.9	V
F	2.9	3.0	V
G	3.0	3.1	V
H	3.1	3.2	V
I	3.2	3.3	V
J	3.3	3.4	V
K	3.4	3.5	V

* Tolerance of measurements of the Forward Voltage is $\pm 0.1V$.

CIE Chromaticity Diagram, IF = 150mA, Ta = 25°C

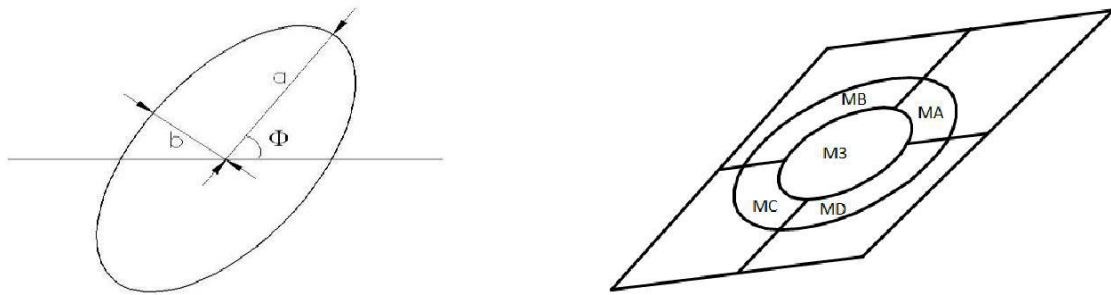

The color ranks have chromaticity ranges within 5-step MacAdam ellipse

CCT	Steps	Center		Radius		Angle(deg)
		x	y	a	b	Φ
2200K	3	0.50987	0.42036	0.0294	0.0144	45.5
2700K	3	0.4649	0.4174	0.0081	0.0042	53.42
3000K	3	0.4426	0.4106	0.00834	0.00408	53.13
3500K	3	0.4154	0.4025	0.00927	0.00414	54.00
4000K	3	0.3918	0.3915	0.00939	0.00402	53.43
5000K	3	0.3530	0.3665	0.00822	0.00354	59.37
5700K	3	0.3392	0.3540	0.006705	0.0033	58.3
6500K	3	0.3192	0.3388	0.00669	0.00285	58.34

* Energy Star binning applied to all 2600~7000K.

* Measurement Uncertainty of the Color Coordinates : $\pm 0.007..$

* Chromaticity Coordinates at 85°C.

CIE Chromaticity Diagram, IF = 150mA, Ta = 25°C

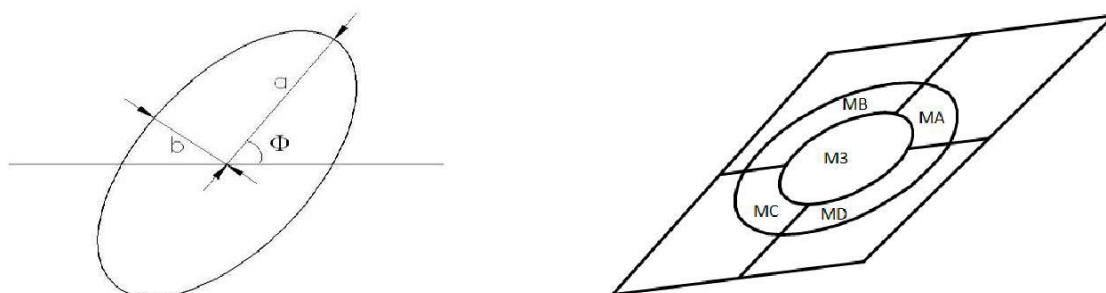

The color ranks have chromaticity ranges within 5-step MacAdam ellipse

CCT	Steps	Center		Radius		Angle(deg)
		x	y	a	b	Φ
1800K	5	0.5592	0.4196	0.0675	0.03500	-35
2200K	5	0.50987	0.42036	0.049	0.02400	45.5
2700K	5	0.4649	0.4174	0.0135	0.00700	53.42
3000K	5	0.4426	0.4106	0.0139	0.00680	53.13
3500K	5	0.4154	0.4025	0.01545	0.00690	54.00
4000K	5	0.3918	0.3915	0.01565	0.00670	53.43
5000K	5	0.3530	0.3665	0.0137	0.00590	59.37
5700K	5	0.3392	0.3540	0.011175	0.00550	58.3
6500K	5	0.3192	0.3388	0.01115	0.00475	58.34

* Energy Star binning applied to all 2600~7000K.

* Measurement Uncertainty of the Color Coordinates : ± 0.007..

* Chromaticity Coordinates at 85°C.

Fig 1. Color Spectrum, Ta = 25°C

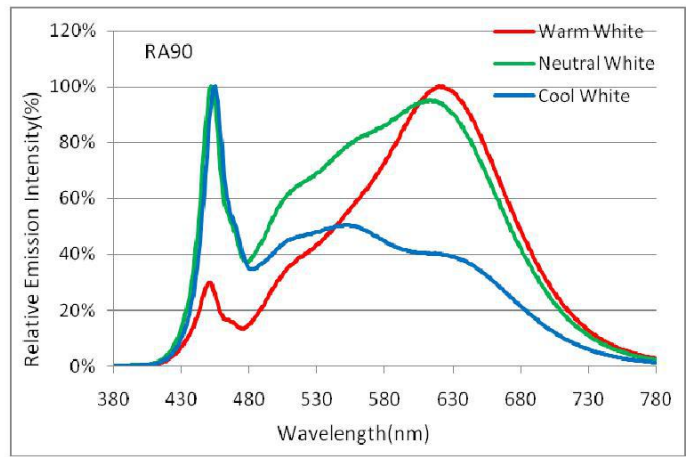
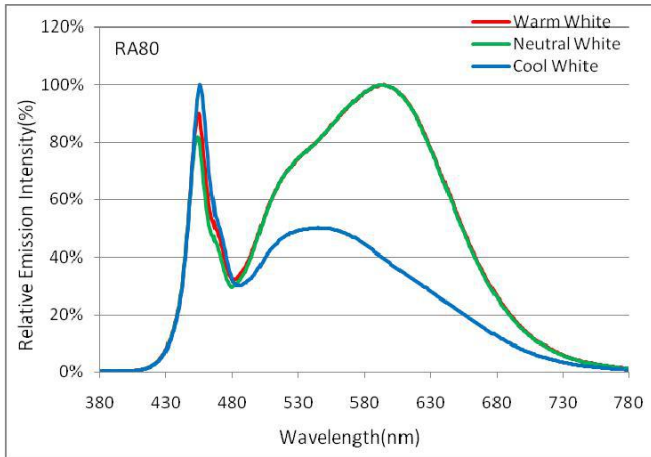

Fig 2. Viewing Angle Distribution, Ta = 25°C

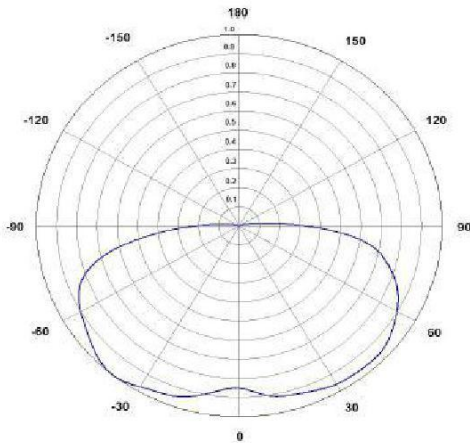

Fig 3. .IF--- Relative Luminous flux, Ta = 25°C

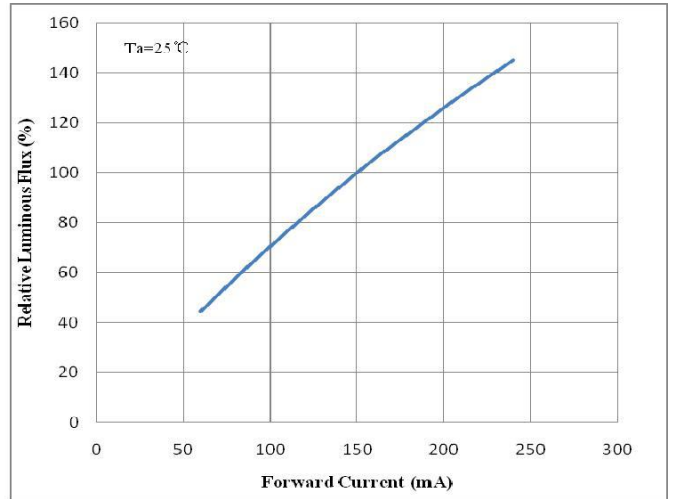

Fig4. . Forward Voltage vs. Forward Current , Ta = 25°C

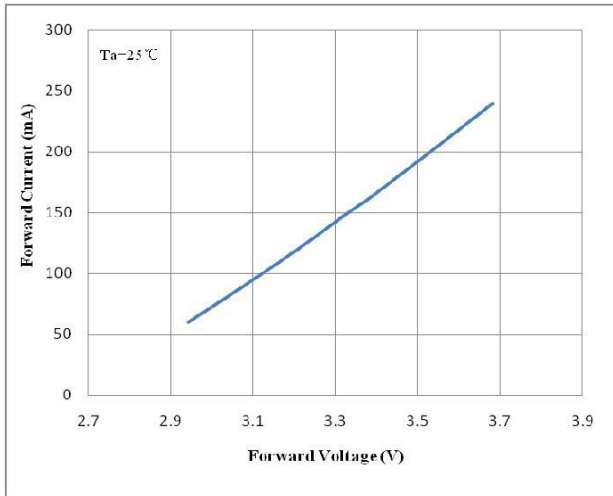

Fig 5. Ta—Relative Luminous flux, Ta = 25°C

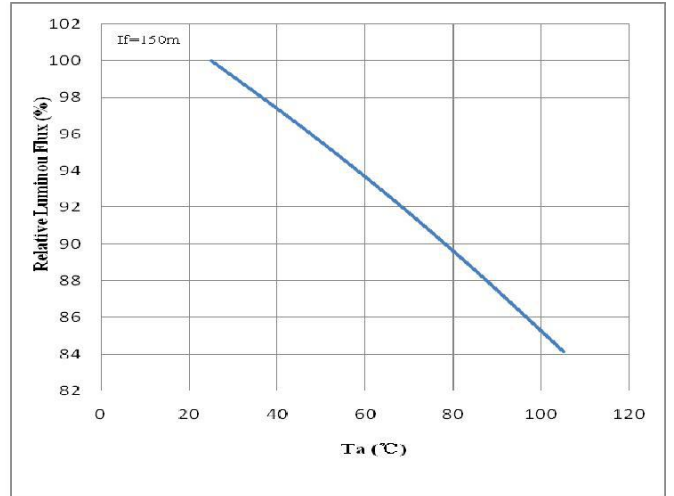

Fig 6. Ta—Forward Voltage, Ta = 25°C

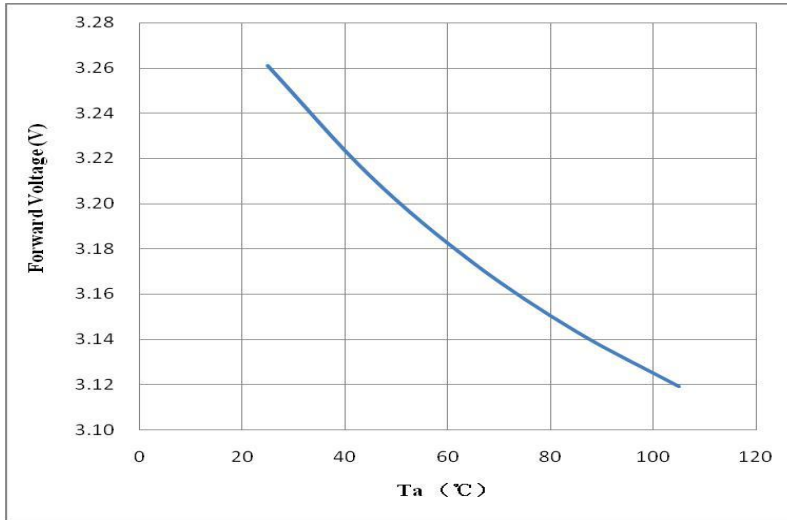

Fig 7, Chromaticity Coordinate vs. Ambient Temperature

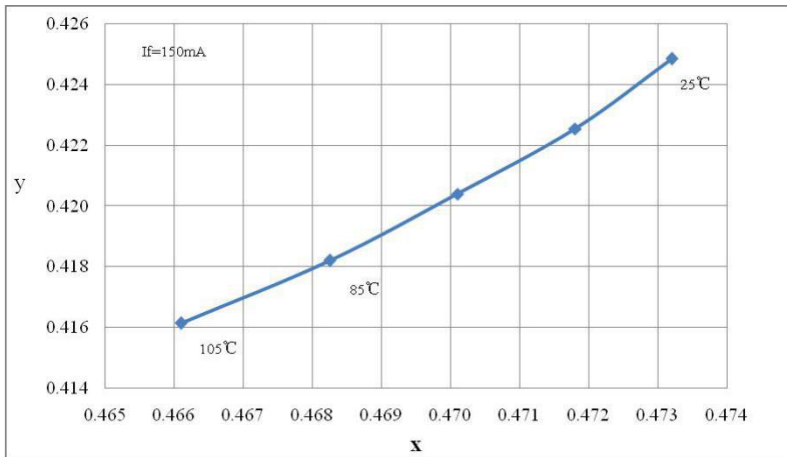
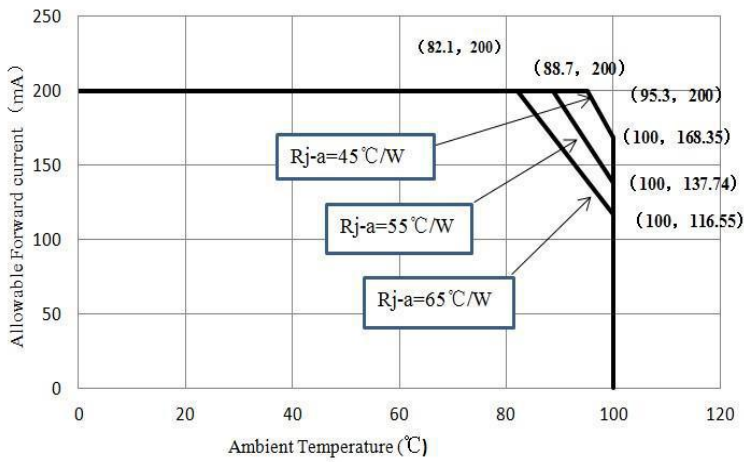
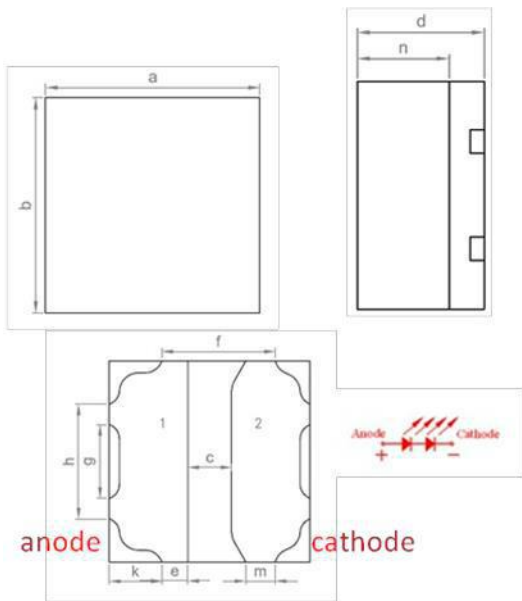

Fig 8, Maximum Forward Current vs. Ambient Temperature



T1S***12A-***6**

Package Dimensions



DIM	MIN	NOM	MAX
a	1.50	1.60	1.70
b	1.50	1.60	1.70
c	0.25	0.35	0.45
d	0.53	0.63	0.73
e	0.11	0.21	0.31
f	0.80	0.90	1.00
g	0.49	0.59	0.69
h	0.81	0.91	1.01
k	0.32	0.42	0.52
m	0.14	0.24	0.34
n	0.28	0.38	0.48

T1S***12A-***9**

Package Dimensions

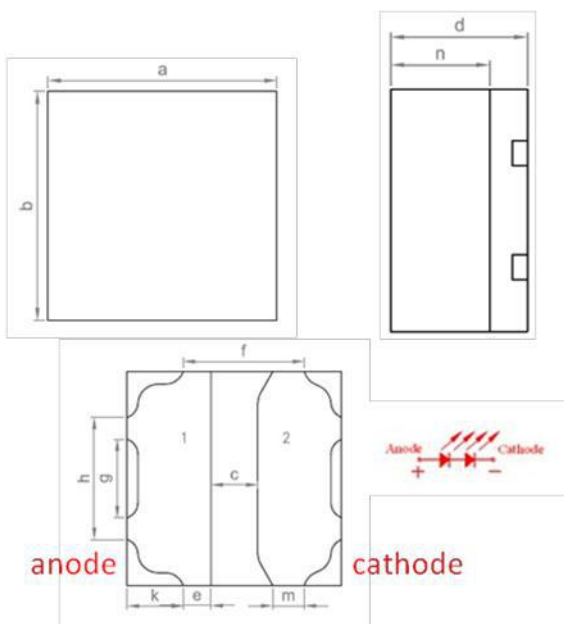

DIM	MIN	NOM	MAX
a	1.50	1.60	1.70
b	1.50	1.60	1.70
c	0.25	0.35	0.45
d	0.80	0.90	1.00
e	0.11	0.21	0.31
f	0.80	0.90	1.00
g	0.49	0.59	0.69
h	0.81	0.91	1.01
k	0.32	0.42	0.52
m	0.14	0.24	0.34
n	0.55	0.65	0.75

- * All dimensions are in millimeters
- * Scale : 1:1
- * Undefined tolerance is $\pm 0.1\text{mm}$

Package Dimensions

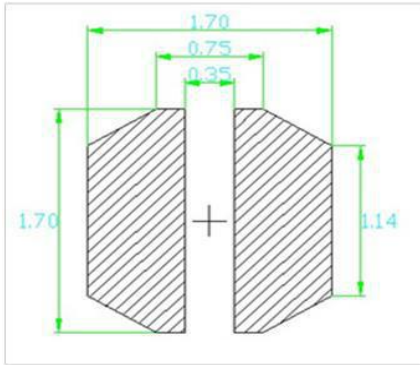

Recommended solder pad

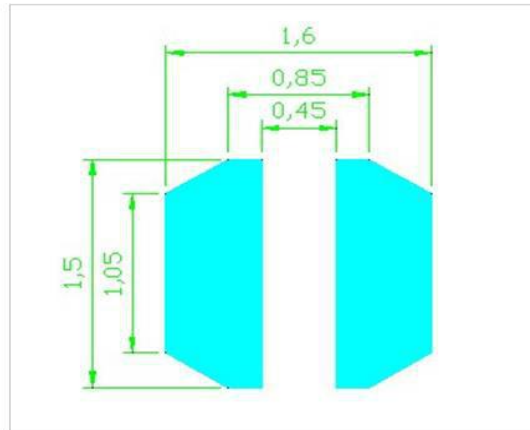

Recommended stencil opening

* All dimensions are in millimeters * Scale : 1:1 *
 Undefined tolerance is $\pm 0.1\text{mm}$

Reflow Soldering Characteristics

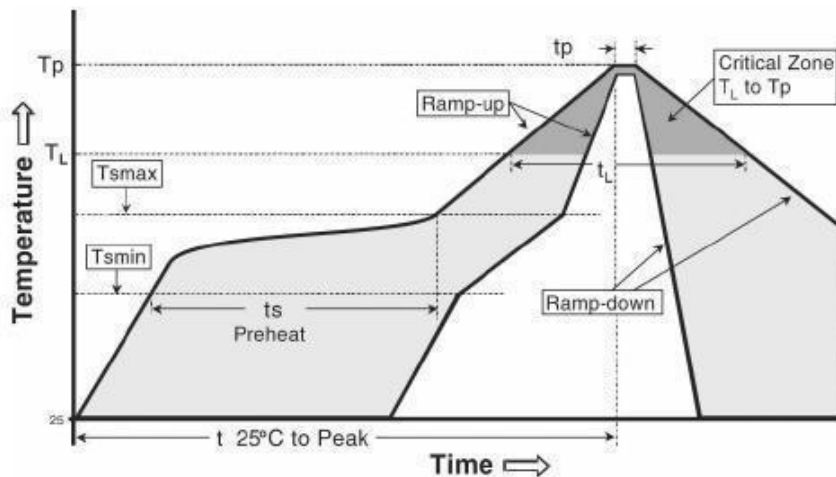

Reflow soldering	
Temperature Min (T _{min})	150° C
Temperature Max (T _{max})	200° C
Time(t _s)from (T _{min} to T _{max})	60-120 seconds.
Ramp-up rate (T _L to T _p)	3° C/seconds max.
Liquidous temperature(T _L)	217° C
Time(t _L) maintained above T _L	60-150 seconds
Peak package body temperature(T _p)	260° C max
Time (t _p) within 5° C of the specified classification temperature (T _c).	30 seconds max
Ramp-down rate (T _p to T _L)	6° C/second max
Time 25 ° C to peak temperature	8 min max

Package Dimensions of Tape

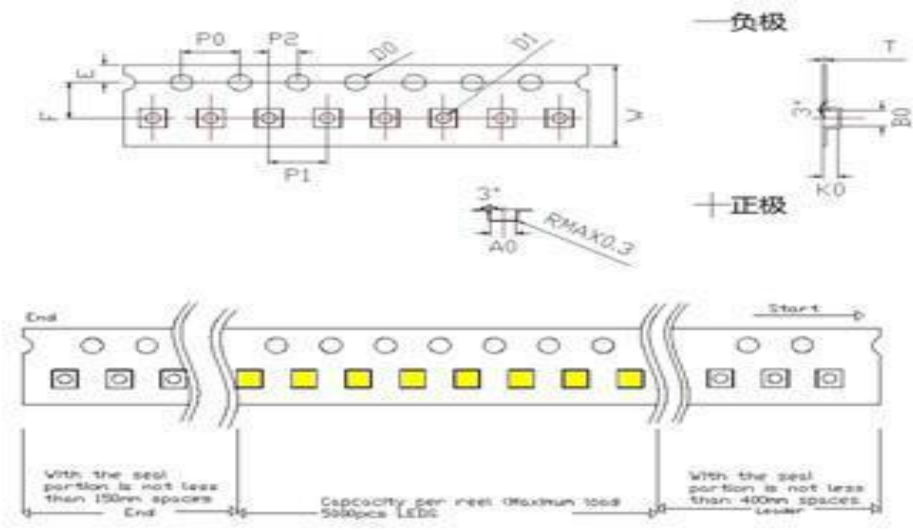

- * Quantity : Max 5000pcs/Reel
- * Cumulative Tolerance : Cumulative Tolerance/10 pitches to be $\pm 0.2\text{mm}$
- * Package : P/N, Manufacturing data Code No. and Quantity to be indicated on a damp proof Package.
- * Adhesion Strength of Cover Tape Adhesion strength to be 0.1-0.7N when the cover tape is turned off from the carrier tape at the angle of 10° to the carrier tape.

Package Dimensions of Reel

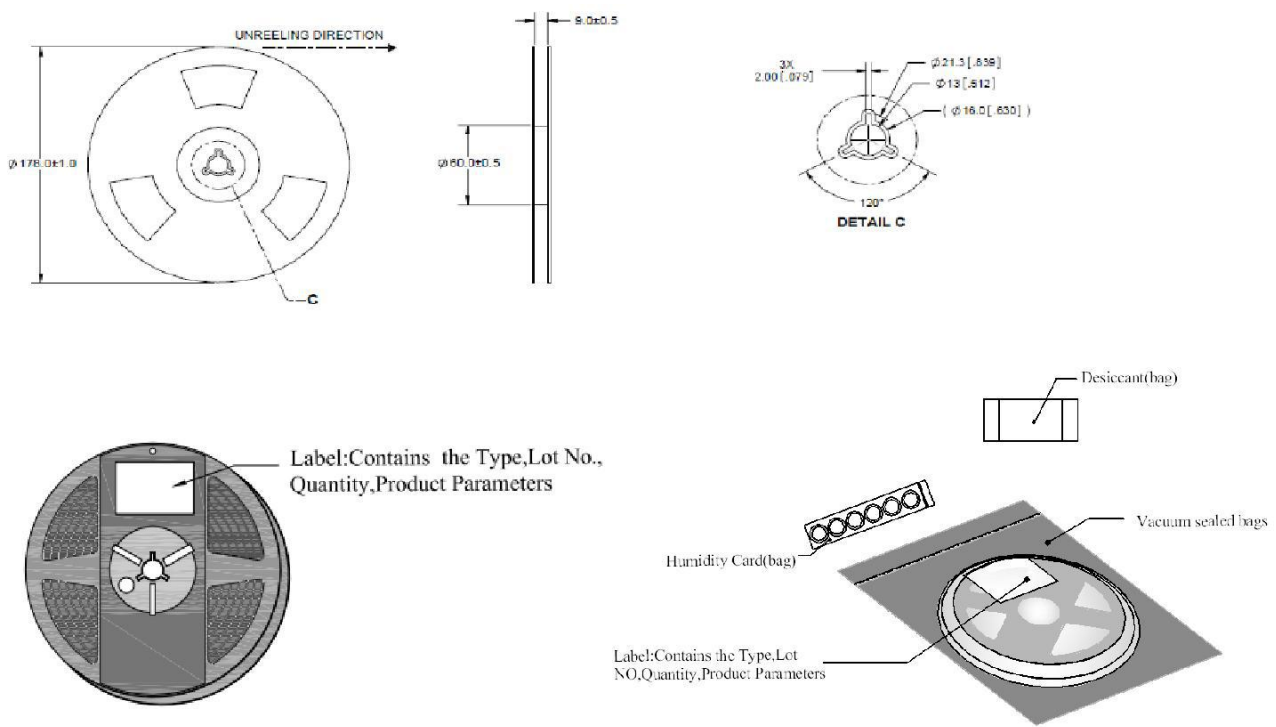

Package Box

Inner Box

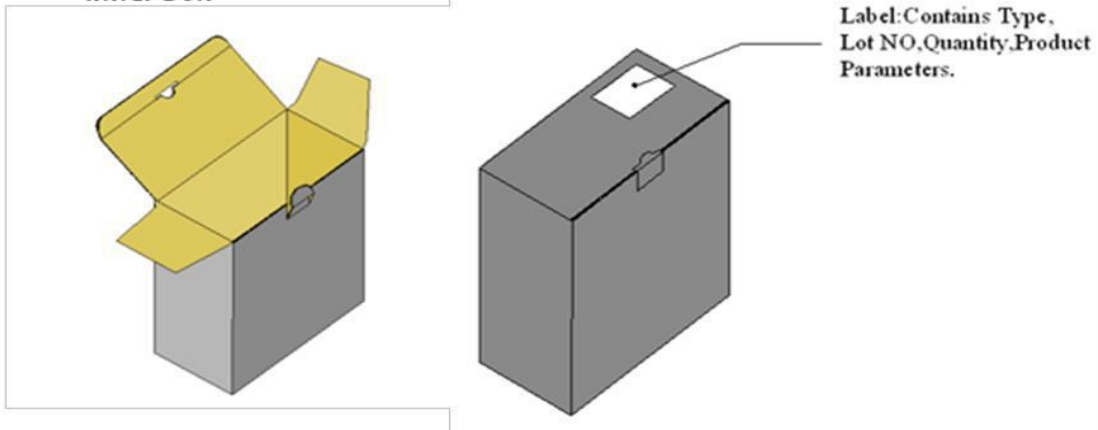

* Capacity 5 or 10 reels per box

Outer Box

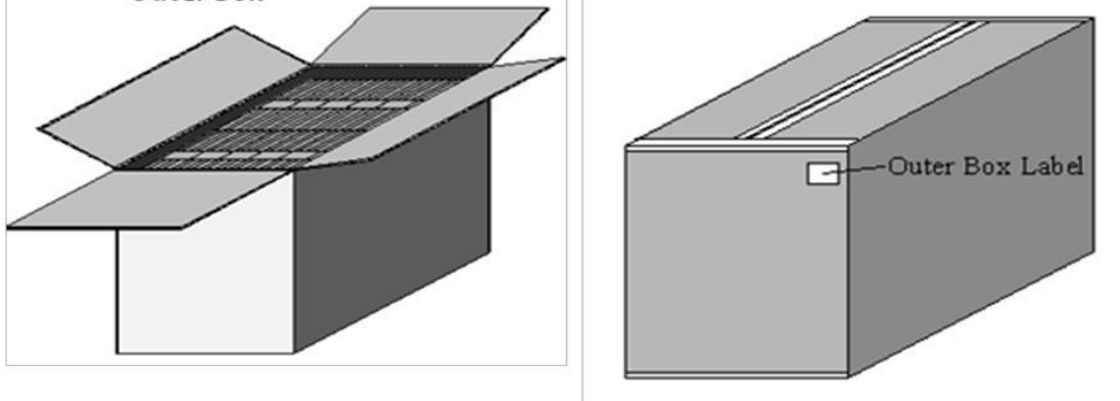

* Capacity 30 or 60 reels per box

Label

Caution

1. Reflow soldering is recommended not to be done more than two times. In the case of more than 24 hours passed soldering after first, LEDs will be damaged.
2. Repairs should not be done after the LEDs have been soldered. When repair is unavoidable, suitable tools must be used.
3. Die slug is to be soldered.
4. When soldering, do not put stress on the LEDs during heating.
5. After soldering, do not warp the circuit board.

Notes on Lightning EMC Series soldering:

1. Recommend to use reflow machine.
2. Recommend to use heating plate soldering.
3. Manual soldering is not recommended.

Notes on reflow process:

1. To confirm whether the actual temperature curve in the reflow soldering conditions comply with recommended conditions. LEDs are guaranteed for one time reflow.
2. During reflow process do not apply force on LED active area.
3. After reflow process, PCB board should be cooled down before packing or storage.

Precaution for use

Storage

1. Before opening the package: The LED should be kept at 30°C or less and 90%RH or less.
2. After opening the package: The LED's floor life is 168Hrs under 30°C or less and 60%RH or less. If unused LED remain, it should be stored in moisture proof packages JEDEC (MSL 3).
3. If the moisture absorbent material (silica gel) has faded away or the LEDs have exceeded the storage time, baking treatment should be performed using the following conditions:
Baking treatment: 60±5°C for 24 hours.