



深圳市锐硕光电有限公司

Shenzhen Ruishuo Optoelectronic Co.,Ltd

SPECIFICATIONS FOR T3C SERIES

WHITE LED

Model : 3030

Part No : T3C***21A-*****

Features:

- * Top view white LED
- * Thermally Enhanced Package Design
- * High luminous flux output
- * High current capability
- * Compact Package Size
- * Wide viewing angle
- * Pb-free Reflow Soldering Application
- * The product itself will remain within RoHS compliant version

**Applications**

- * Retrofits(replacement)
- * General lighting
- * Indoor & Outdoor sign board back light
- * Architectural / Decorative lighting

Part Numbering System

T □□ □□ □ □ □ □ - □ □□ □□ □

X1 X2 X3 X4 X5 X6 X7 X8 X9 X10

Item Number Code	Description	Content
X1	Type code	1S:1010; 1A:1919; 20:2016; 3B:3014; 28:2835 34:3020; 3C:3030; 5C:5050; 7C:7070; 1D:100100; 19: Ceramic 3535; 15: Ceramic 5050; 11: Ceramic 1616.
X2	CCT code	2700K:27; 3000K:30; 4000K:40; 5000K:50; 5700K:57; 6500K:65.
X3	Color Rendering	Ra70:7; Ra80:8; Ra90:9.
X4	No. of serial chip	1-Z.
X5	No. of parallel chip	1-Z.
X6	Component code	A-Z.
X7	Color Code	M:ANSI; F:ERP; R:85°C ANSI; T:105°C ANSI; B:Backlighting; Q:Others;AT:Tospo
X8	Internal code1	\
X9	Internal code2	\
X10	Spare code	\

Electro Optical Characteristics, IF = 120mA, Tj=25°C

CCT	Color Rendering	Luminous Flux	
	Min.	Typ.	Min.
2700K	70	105	95
	80	100	90
	90	84	75
3000K	70	109	100
	80	105	95
	90	87	80
4000K	70	114	105
	80	109	100
	90	91	85
5000K	70	114	105
	80	109	100
	90	91	85
5700K	70	114	105
	80	109	100
	90	91	85
6500K	70	114	105
	80	109	100
	90	91	85

* Tolerance of measurements of the Luminous Flux is $\pm 7\%$.

* Ra measurement tolerance is ± 2 .

Absolute Maximum Ratings at Tj=25°C

Item	Symbol	Absolute Maximum Rating	Unit
Forward current	IF	200	mA
Pulse Forward current	I _{FP}	300	mA
Power Dissipation	PD	1280	mW
Reverse Voltage	VR	5	V
Operating Temperature	Topr	-40~+105	°C
Storage Temperature	Tstg	-40~+85	°C
Junction Temperature	Tj	120	°C
Soldering Temperature	Tsld	Reflow Soldering: 230°C or 260°C for 10sec	

* IFP condition with Pulse: Width≤100μs, Duty cycle≤1/10.

* LED's properties might be different from suggested values like above and below tables if operation condition will be exceeded our parameter range. Care is to be taken that power dissipation does not exceed the absolute maximum rating of the product.

* All measurements were made under the standardized environment of Lightning LED.

Electrical/Optical Characteristics at Tj=25°C

Item	Symbol	Min	Typ	Max	Unit	Condition
Forward Voltage	VF	5.6	6.0	6.4	V	IF = 120mA
Reverse Current	IR	-	-	10	μA	VR=5V
Viewing Angle	2θ _{1/2}	-	120	-	°	IF = 120mA
Thermal Resistance	(Rth j-sp)	-	17	-	°C/W	IF = 120mA
Electrostatic Discharge	ESD	1000	-	-	V	HBM

* Tolerance of measurements of the Forward Voltage is ±0.2V.

* 2θ_{1/2} is the off-axis where the luminous intensity is 1/2 of the peak intensity.

* Rth j-sp is the thermal resistance from LED junction to solder point on MCPCB with electrical power.

Bin Structure

Luminous Flux Ranks, IF = 120mA, Tj =25°C

CCT	Color Rendering		Luminous Flux		
	Min.	Typ.	Code	Min	Max
2700K	70	72	5D	95	100
			5E	100	105
			5F	105	110
			5G	110	115
	80	82	5C	90	95
			5D	95	100
			5E	100	105
			5F	105	110
	90	92	1X	75	80
			5A	80	85
			5B	85	90
			5C	90	95
3000K	70	72	5E	100	105
			5F	105	110
			5G	110	115
			5H	115	120
	80	82	5D	95	100
			5E	100	105
			5F	105	110
			5G	110	115
	90	92	5A	80	85
			5B	85	90
			5C	90	95
			5D	95	100
4000K/5000K /5700K/6500K	70	72	5F	105	110
			5G	110	115
			5H	115	120
			5J	120	125
	80	82	5E	100	105
			5F	105	110
			5G	110	115
			5H	115	120
	90	92	5B	85	90
			5C	90	95
			5D	95	100
			5E	100	105

* Tolerance of measurements of the Luminous Flux is $\pm 7\%$.

* Ra measurement tolerance is ± 2 .

Forward Voltage Ranks, IF = 120mA, Tj = 25°C

Code	Min	Max	Unit
Z3	5.6	5.8	V
A4	5.8	6.0	V
B4	6.0	6.2	V
C4	6.2	6.4	V

* Tolerance of measurements of the Forward Voltage is $\pm 0.2V$.

CIE Chromaticity Diagram, IF = 120mA, Tj = 25°C

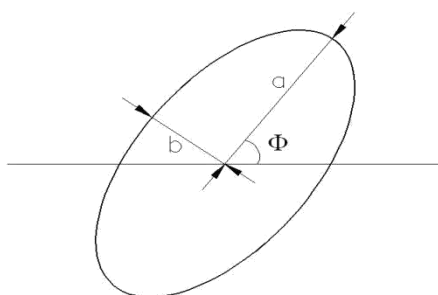

The color ranks have chromaticity ranges within 5-step MacAdam ellipse

Color Code	Center (Tj=25°C)		Center (Tj=85°C)		Radius		Angle(deg)
	x	y	x	y	a	b	Φ
27R5	0.4620	0.4145	0.4578	0.4101	0.013500	0.007000	53.42
30R5	0.4383	0.4081	0.4338	0.4030	0.013900	0.006800	53.13
40R5	0.3875	0.3868	0.3818	0.3797	0.015650	0.006700	53.43
50R5	0.3507	0.3635	0.3447	0.3553	0.013700	0.005900	59.37
57R5	0.3348	0.3491	0.3287	0.3417	0.011175	0.005500	58.35
65R5	0.3187	0.3363	0.3123	0.3282	0.011150	0.004750	58.34

* Energy Star binning applied to all 2600~7000K.

* Tolerance of measurements of the chromaticity Coordinate is ± 0.005 .

Fig 1. Color Spectrum, Tj = 25°C, Ra = 70

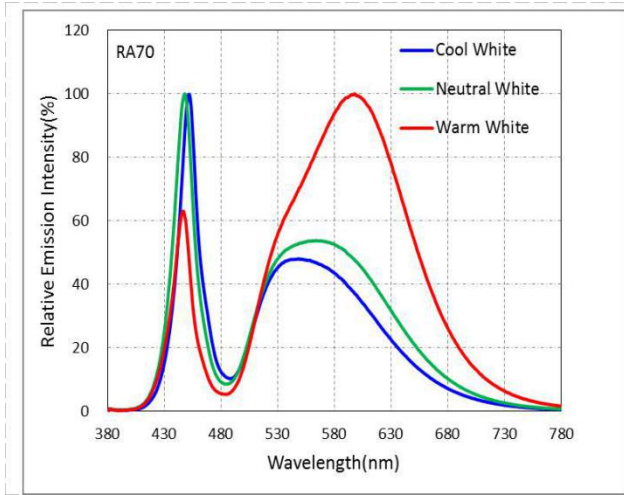

Fig 2. Color Spectrum, Tj = 25°C, Ra = 80

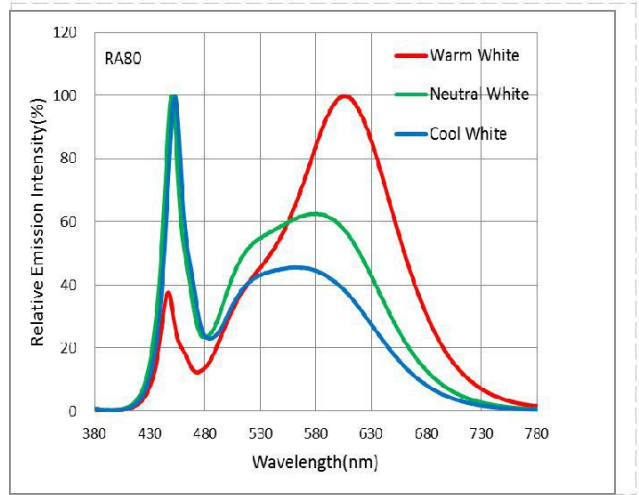

Fig 3. Color Spectrum, Tj = 25°C, Ra = 90

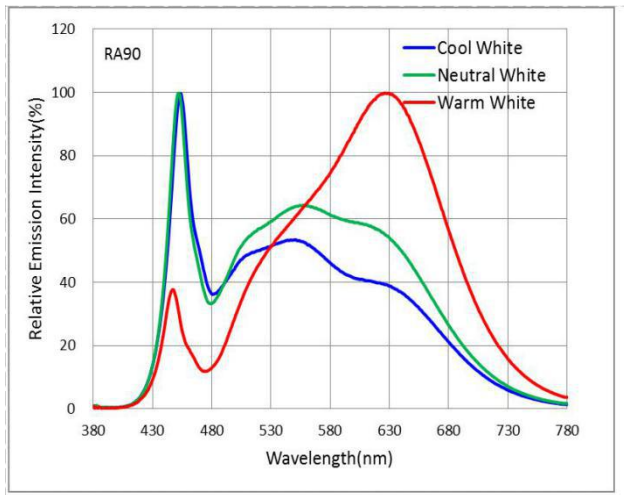

Fig 4. Viewing Angle Distribution, Tj = 25°C

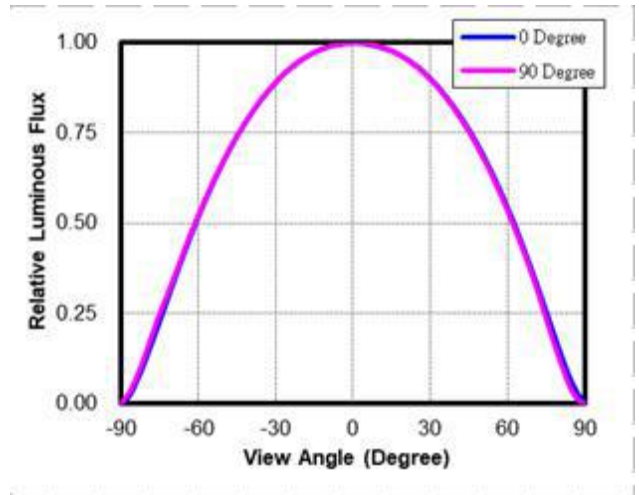

Fig 5. Forward Current vs. Relative Intensity, Tj = 25°C

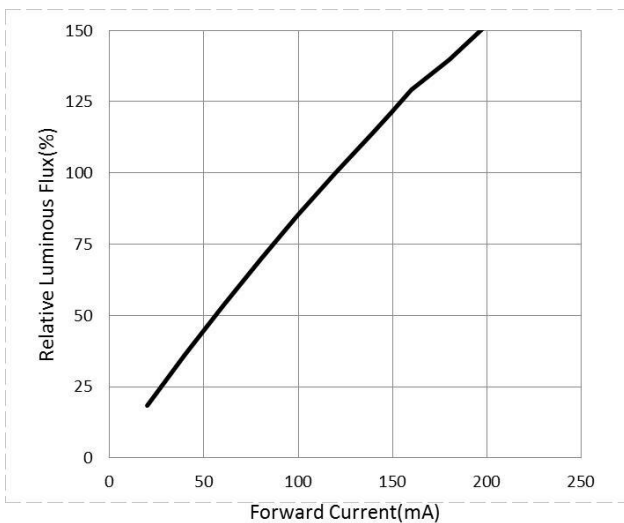
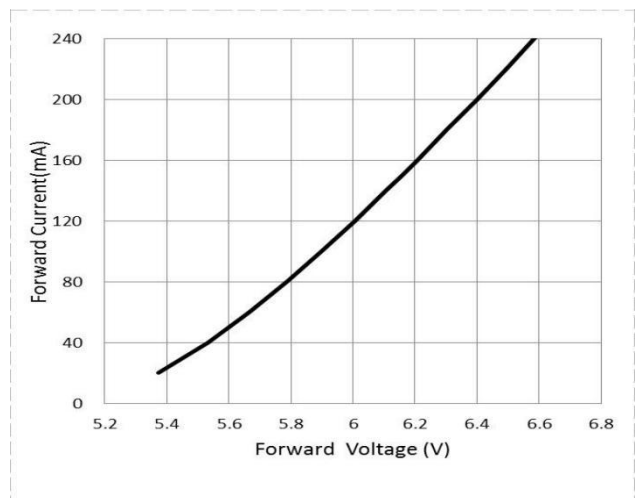
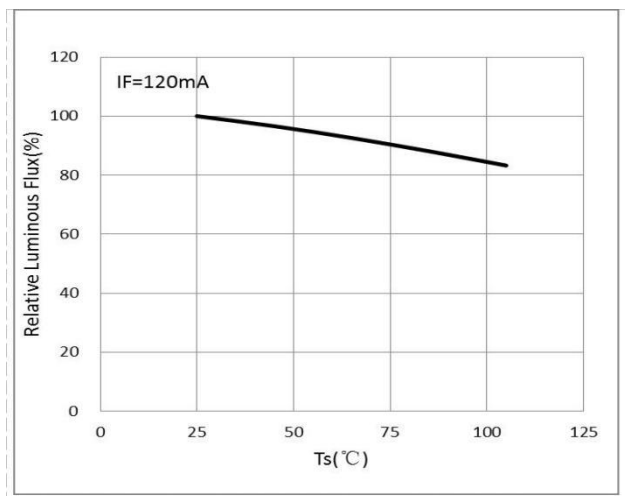

Fig 6. Forward Current vs. Forward Voltage, Tj = 25°C



**Fig 7. Ambient Temperature vs. Relative Luminous flux
(IF=120mA)**



**Fig 8. Ambient Temperature vs. Relative Forward Voltage
(IF=120mA)**

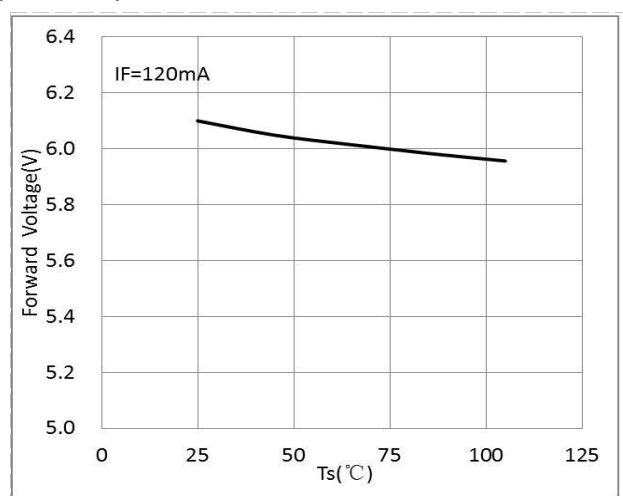

Package Dimensions

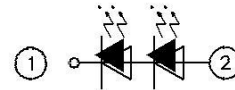
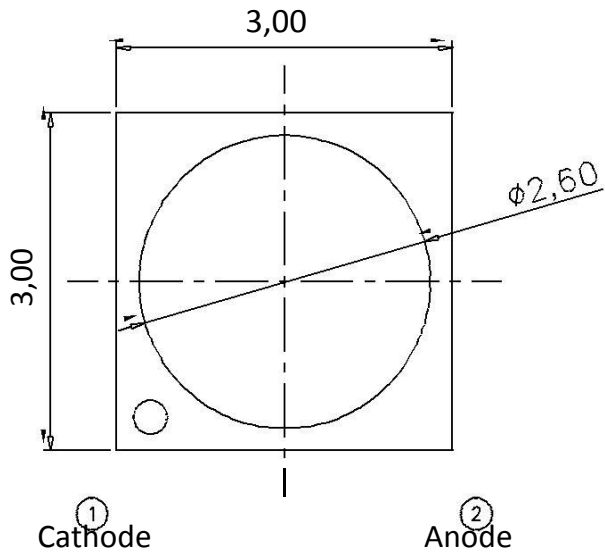

Polarity

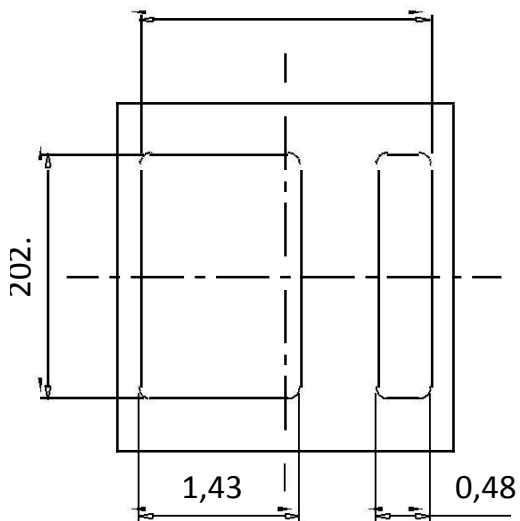
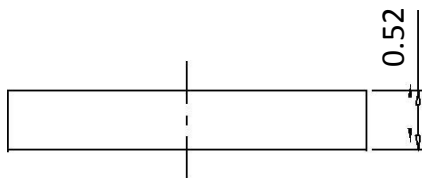

Bot. view

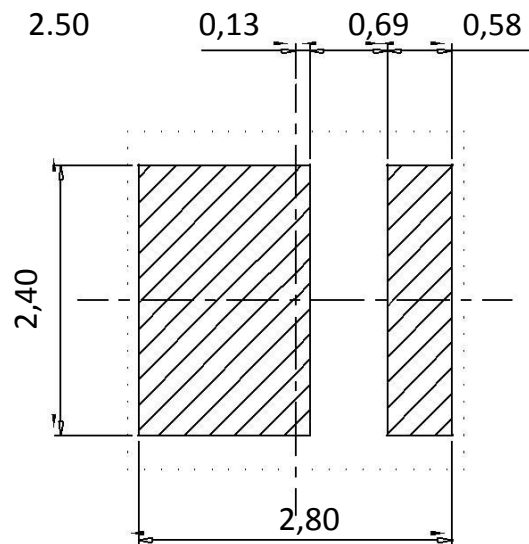

Soldering patterns

* The tolerance unless mentioned is $\pm 0.1\text{mm}$, unit = mm

Reflow Soldering Characteristics

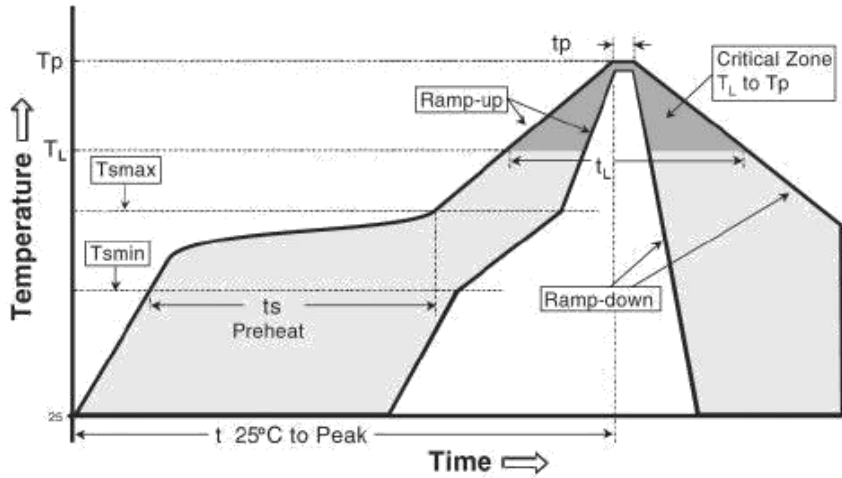

Reflow soldering	
Temperature Min (T _{min})	150° C
Temperature Max (T _{max})	200° C
Time(t _s)from (T _{min} to T _{max})	60-120 seconds.
Ramp-up rate (T _L to T _p)	3° C/seconds max.
Liquidous temperature(T _L)	217° C
Time(t _L) maintained above T _L	60-150 seconds
Peak package body temperature(T _p)	260° C max
Time (t _p) within 5° C of the specified classification temperature (T _c).	30 seconds max
Ramp-down rate (T _p to T _L)	6° C/second max
Time 25 ° C to peak temperature	8 min max

Package Dimensions of Tape

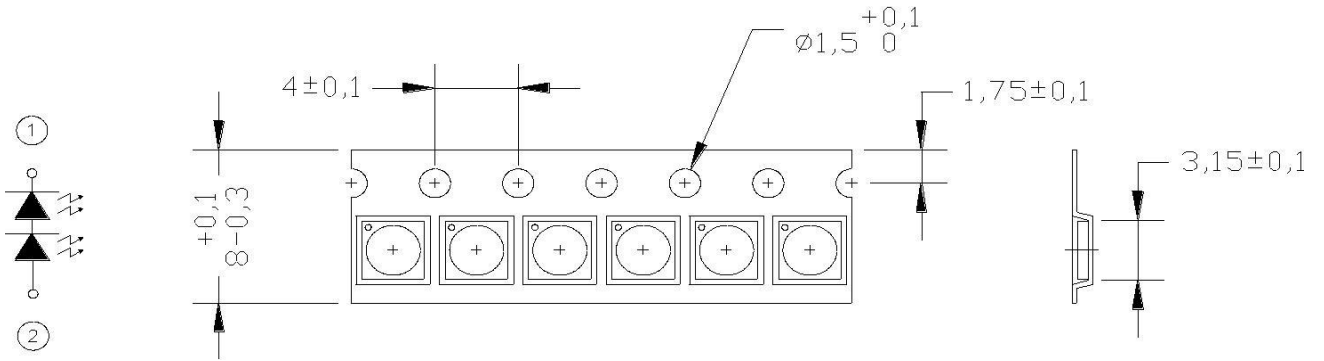

- * Quantity : Max 5000pcs/Reel
- * Cumulative Tolerance : Cumulative Tolerance/10 pitches to be ± 0.2 mm
- * Package : P/N, Manufacturing data Code No. and Quantity to be indicated on a damp proof Package.
- * unit = mm

Package Dimensions of Reel

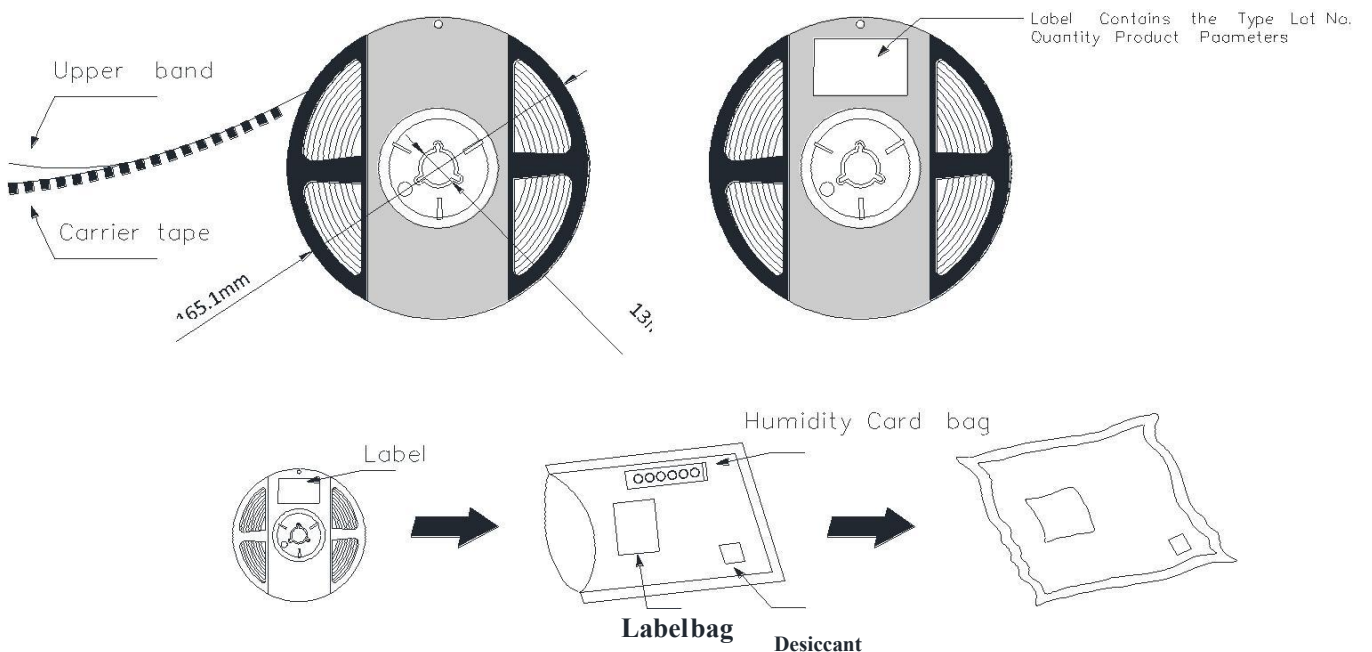

Package Box

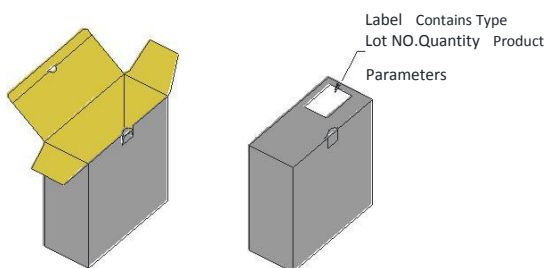

* Capacity 10 reels per box.

Outer Box

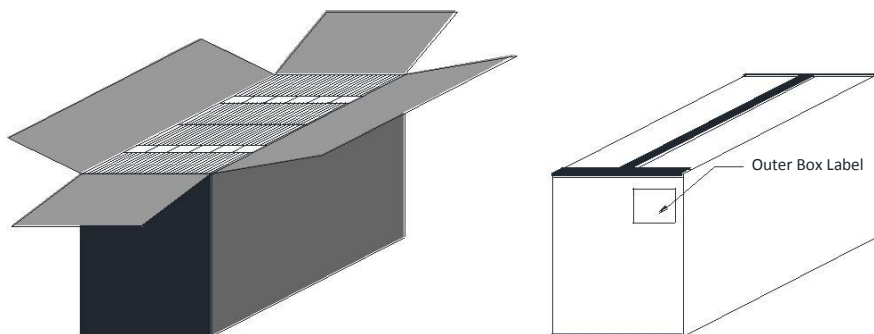

* Capacity 30 or 60 reels per box.

Label



Caution

1. Reflow soldering is recommended not to be done more than two times. In the case of more than 24 hours passed soldering after first, LEDs will be damaged.
2. Repairs should not be done after the LEDs have been soldered. When repair is unavoidable, suitable tools must be used.
3. Die slug is to be soldered.
4. When soldering, do not put stress on the LEDs during heating.
5. After soldering, do not warp the circuit board.

Notes on Lightning EMC Series soldering:

1. Recommend to use reflow machine.
2. Recommend to use heating plate soldering.
3. Manual soldering is not recommended.

Notes on reflow process:

1. To confirm whether the actual temperature curve in the reflow soldering conditions comply with recommended conditions. LEDs are guaranteed for one time reflow.
2. During reflow process do not apply force on LED active area.
3. After reflow process, PCB board should be cooled down before packing or storage.

Precaution for use

Storage

1. Before opening the package: The LED should be kept at 30°C or less and 90%RH or less.
2. After opening the package: The LED's floor life is 168Hrs under 30°C or less and 60%RH or less. If unused LED remain, it should be stored in moisture proof packages JEDEC (MSL 3).
3. If the moisture absorbent material (silica gel) has faded away or the LEDs have exceeded the storage time, baking treatment should be performed using the following conditions:
Baking treatment: 60±5°C for 24 hours.